

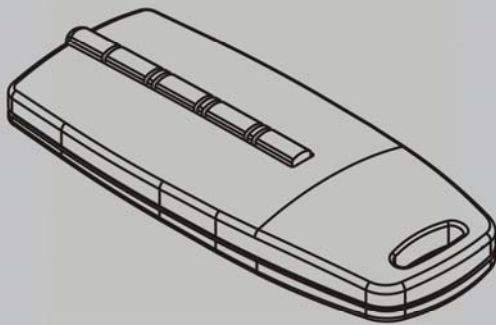

RDO-10A

Roller Door Opener



- * Safety Obstruction Detection
- * Rolling Code Security
- * Anti Theft Security System
- * Automatic Closing
- * Automatic Courtesy Light

IMPORTANT SAFETY RECOMMENDATIONS

FAILURE TO COMPLY WITH THE FOLLOWING SAFETY RECOMMENDATIONS MAY RESULT IN SERIOUS PERSONAL INJURY, DEATH AND/OR PROPERTY DAMAGE

- **The installation of the Automatic Garage Door Opener (Opener) must be carried out by a technically qualified or licensed person. Attempting to install the Opener without suitable technical qualification may result in severe personal injury, death and/or property damage.**
- Only install the Opener on a well functioning, properly balanced and aligned garage door. An improperly balanced or malfunctioning garage door could cause serious injury. Have a qualified person check and if required, make repairs to the door before installing the Opener. As a general rule a garage door is deemed to be well balanced and aligned if it; A. requires an equivalent amount of applied force to manually open or close and, B. requires no more than 150N (15kg) of applied force to either manually open or close and, C. does not rise or fall more than 100mm when stopped at any position between fully open or fully closed positions and, D. Does not rub on or make contact with any supporting or surrounding structures.
- Repairs to garage doors must only be carried out by technically qualified persons. Attempting to repair the garage door without suitable technical qualification may result in severe personal injury, death and/or property damage.
- Remove or render inoperative all existing locks and ropes prior to installation of the Opener.
- Adjust the disengage cord so that it hangs approximately 1.8 meters from the ground. The instruction tag must remain attached to the disengage cord.
- Do not connect the Opener to the power source until this manual instructs you to do so.
- The Opener must be connected to a properly earthed general purpose 220 - 240V power outlet.
- Locate the wall control panel/push button; A. within site of the garage door and, B. at a minimum height of 1.5 meters above the ground so that it remains out of the reach of small children and, C. away from all moving parts of the door.
- **Affix the entrapment warning label in a prominent position adjacent to the garage door.**
- **After installing and adjusting the Opener the door must stop and reverse direction when it comes into contact with a 40 mm high solid object placed under it on the floor.**
- **The correct function of the safety reversing system should be checked on a monthly basis. Make sure that the door reverses easily when it makes contact with an obstruction.**
- **Never use the Opener unless the door is in full view and free from objects such as cars, children and/or adults.**
- **Never allow children to use the Opener.**
- **Never use the Opener when children/persons are under or near the path of the door. Children must be supervised at all times when near the door and when the Opener is in use.**
- **Never attempt to disengage the Opener when there are children/persons or and other objects including motor vehicles under or near the path of the door.**
- **Removal of the screw-on protective covers must only be performed by a technically qualified person. Attempting to remove the protective covers or repair the Opener without suitable technical qualification may result in personal injury, death and/or property/product damage.**
- **Never attempt to make any repairs or remove any screw-on covers from the Opener without first disconnecting the power supply cord from main power supply.**
- **Always ensure that the garage door is fully open before driving into or out of the garage.**
- **Always ensure the door is fully closed before leaving the driveway.**
- **Adjustments to the safety reverse force settings must be carried out in strict accordance with the procedure set out in this manual. Failure to do so may result in severe personal injury, death and/or property damage.**
- **Keep hands and loose clothing clear of the door at all times.**
- **For the safety reverse system to function it must first exert force on an object/person/obstruction. As a result the object/person/door may suffer damage or injury.**
- **The safety reverse system is designed to work on STATIONARY objects only. If the door encounters a moving object during an Open or Close Cycle, serious personal injury, death and/or property/product damage may occur**

	Page	Diagram
Safety Recommendations.....	3	
Installation Instructions.....	4.....	1 - 8
Settings and Adjustments	5.....	9 - 13
Transmitter Learning.....	5.....	9
Engaging / Disengaging.....	5.....	10
Door Travel Adjustment.....	5.....	11
Safety Reverse.....	6.....	12
Options and Features.....	7.....	13
Auto Close.....	7.....	13
Courtesy Lamp	7.....	13
Door Service Monitor.....	7.....	13

	Page	Diagram
LED Indicator.....	7.....	13
Partial Reverse.....	7.....	13
Safety Beams.....	7.....	13
Soft Stop.....	7.....	13
Speed Control.....	7.....	13
Terminal Connections.....	7.....	13
Vacation Mode.....	7.....	13
Installation Diagrams	8	2 - 9
Connection Diagram	9	10 -13
Exploded View Diagram	10 ...	
Notes	11 ...	

INSTALLATION INSTRUCTIONS

The procedures outlined in this manual require a degree of technical and mechanical skill. It is not recommended that the Opener be installed by a home handyman. The Opener should be installed and adjusted by a technically qualified person. Never install the Opener on a poorly adjusted or worn garage door.

Important Note: The numbered sections in the manual correspond with numbered pictures at the end the manual

1. Check for Correct Function of the Garage Door

- Before commencing installation of the Opener check that the garage door is functioning correctly. It must be well balanced and operate smoothly and freely and not bind or stick in the side tracks.
- When released from any position it should not rise or fall more than 100mm. The effort required to open or close the door by hand should not exceed 150N (15kg).

2. Check Side Room Requirement

- The min and max mounting positions, as measured from the edge of the door curtain to the inner edge of its mounting bracket are 40 and 50mm.
- If the distance is less than 40mm or more than 50mm then door bracket must be moved so as to fall within the bounds of these 2 dimensions (see Fig. 2, p.8).

3. Select Installation Side

- Determine to which end of the door the Opener will be installed and select the dip switch according to the following:
- Left Hand Side Installation - Dip 6 "ON" (Fig.9) Right Hand Side Installation - Dip 6 "OFF" (Fig.9)

4. Fit Opener to Door (Right Hand Installation Described)

- Remove or render inoperative all existing door locks.
- Ensure that the door bracket to which the Opener will be installed is the correct distance from the edge of the curtain.
- Check and ensure that the fastening U-bolt is securely tightened on the opposite end of the door.
- Open the door fully and ensure that the door stoppers have engaged with track stoppers.
- Place a prop under the door as close to the edge as possible and is adjusted so that it sits firmly under the garage door).
- Check U-bolt on opposite side of door to the side the motor is to be fitted to ensure tight (see Fig. 4, p. 8).
- Remove the U-bolt from the door bracket and then remove the door mounting bracket from the wall, motor side.
- Orient the Opener so that its 2 forks line up with the narrowest of the garage door drum wheel spokes.
- Slide the Opener onto the door axle and push it fully into the door so that it sits against the drum wheel.
- Refit the door mounting bracket to the wall making sure to tighten the mounting bracket screws securely.
- Insert the U-bolt supplied through the Opener and door bracket slots and then secure with the nuts and washers provided.
- Check the manual operation of the door by fully raising and lowering it several times and ensure it runs smoothly and does not catch on any part of the Opener

5. Pin Curtain to Drum Wheel

- The door curtain must be secured to the drum wheel with self drilling screws at both sides of the door.
- With the door **fully closed**, mark the curtain at points "A" and "B" ensuring that the fixing points are at least 90 deg apart.
- Open the door slightly so as to have access to the marked positions then secure the curtain to the drum wheel as depicted.
- Ensure screws do not interfere with the running of the door or operator (see Fig. 5, p.8).

6. Fit Weight Bar

- Where provided fix the weight bar to the top edge of the door rail with the screws and nuts provided.

7. Attach Entrapment Warning Label

- Attach the Entrapment Warning Label to the wall in a prominent position adjacent to the Opener.

8. Connect to Power Supply

- Connect to a properly earthed power supply using the power cord provided
- **Important Note: Ensure that the power cord does not touch the moving door and that no excess cord hangs below the Opener when it is plugged in.**
- The Opener is now installed and ready for adjustment.

SETTINGS AND ADJUSTMENTS

The following section outlines the selectable options and features which are available to the user. The Control Box cover must be removed in order to access the components which control these features. Switch off power at power outlet - hinge down the light cover and remove the single retaining screw and then unclip the cover from its base.

9. Engaging & Disengaging the Opener

Important Note: Always disengage the Opener with the door in the fully closed position. If disengaging from any position other than the door fully closed ensure that there are no persons or property near or directly under the path of the door.

To Disengage

- Pull down on the red release cord

To Engage

- Pull down on the green release cord

10. Transmitters – Learning & Deleting

Important Note: Hand transmitters and wall panel are supplied pre learned as per the diagrams located on the back page of this manual. To delete or learn transmitter codes refer to the instructions outlined in this section

A. Mass Learning

Function – Learns ALL 4 transmitter buttons as follows:

1. Run 2. Auto Close Override 3. Courtesy Light 4. Vacation Mode

To Learn – Press (red) Learn button (2) – LED (1) single blinks

Press any Transmitter (4) button twice – learn complete

B. Run A Function Learning

Function – Learns only Run button.

To Learn – Press (red) Learn button (2) twice – LED (1) double blinks.

Press desired Transmitter (4) button twice – learn complete

C. Run B Function Learning

Function – Door will not auto close when opened from this button.

To Learn – Press (red) Learn button (2) 3 times – LED (1) triple blinks

Press desired Transmitter button (4) twice – Learn complete

D. Courtesy Light On/Off Function Learning

Function – Turns courtesy light on/off

To Learn – Press (red) Learn button (2) 4 times – LED (1)

quadruple blinks

Press desired Transmitter button (4) twice – Learn complete

E. Vacation Mode Function Learning

Function – Disables Learn and Run button function

To Learn – Press (red) Learn button (2) 5 times – LED (1) quintuple blinks

Press desired Transmitter button (2) twice – Learn complete

F. Wireless Wall Switch

The wireless wall switch can be programmed in the same way as a transmitter.

Select one of the methods outlined in parts A – G and Learn accordingly.

G. Deleting all Transmitters

Momentarily press (red) Learn button (2) – LED (1) single blinks

Press and hold (black) Run button (3) – LED rapid blinks
Transmitters deleted once LED ceases to blink

H. Battery Replacement

Follow the procedure outlined in diagram 10H

Replace the battery with one of identical specification

11. Door Travel Adjustment

When adjusting limits always ensure that the Opener is disengaged from the door and not connected to the power supply

Open Direction

- Move the door by hand to the fully open position.
- Remove the light cover to expose the Limit Cams.
- Slightly loosen the 3 lock screws so that the Cams can be rotated by hand with a firm push.
- Rotate the “Open” Cam in the direction of the limit switch until the switch is heard to “click”.
- Once the switch “clicks” continue to rotate the cam a further 5 degrees **towards** the switch.
- Check adjustment by partially raising and lowering the door by hand. The switch should “click” approx 50mm **before** the door stoppers reach the track stoppers.
- If necessary adjust the Open Limit Cam accordingly - turn the cam **towards** switch to **decrease** door travel and **away** from the switch to **increase** door travel.

Close Direction

- Move the door by hand to the fully closed position.
- Rotate the “Close” Cam in the direction of the limit switch until the switch is heard to “click”.
- Once the switch “clicks” rotate the cam by 5 degrees back away from the switch.
- Check adjustment by partially raising and lowering the door by hand. The switch should “click” approx 20mm **before** the door reaches the ground.
- If necessary adjust the Close Limit Cam accordingly - turn the cam **towards** switch to **decrease** door travel and **away** from the switch to **increase** door travel.

SETTINGS AND ADJUSTMENTS

12. Safety Reverse

During a closing movement Auto Reverse ensures that the garage door will stop and reverse (Auto Reverse) when it encounters an obstruction thus ensuring the safety of people and property. During an opening movement the garage door will stop (Safety Stop) when it encounters an obstruction. The amount of force required to make the garage door Safety Reverse or Safety Stop can be adjusted. A low force value ensures maximum safety, but requires a very well sprung and installed door in order to avoid ghosting (false safety reversing or stopping). A high force value ensures that even a badly sprung or worn door will work without ghosting. The following details the correct force value set up and adjustment procedure.

A MODE

- **Description**

The most sensitive system best suited for use on new well sprung doors - automatically compensates on each and every cycle for door wear ageing and seasonal temperature change for the lifetime of the door.

- **Function** – During a closing movement the Opener will stop and commence to Safety Reverse upon encountering an obstruction.

- **Enabling**

Switch power off at power outlet.
Remove the light cover.
Select Dip 1 to “ON” position.

- **Learning**

In order to Learn Safety Reverse and Safety Stop values the Opener will be required to complete 6 (transmitter or run button (3) initiated) uninterrupted open and close cycles. During the learning process the LED (1) will rapid blink. Once learning has been completed the LED will extinguish.

- **Adjustment**

Rotate the green “Offset” Adjust Pin (4) in a clockwise direction (towards Max) to increase the amount of force required to make the garage door Safety Reverse or Safety Stop and in an anti clockwise direction (towards Min) to decrease the amount of Force required to make the garage door Safety Reverse or Safety Stop.

- **Testing Open Direction**

During an open cycle apply some firm downward force to the garage door. If the Safety Stop value is correct the Opener will stop upon sensing the resistance. If too little or too much force is required to make the opener stop turn the green “Offset” Adjust Pin (4) 5 degrees in the

appropriate direction – clockwise to increase the amount of force – anti clockwise (Min) to decrease the amount of force – and then repeat the test.

- **Testing Close Direction**

Ensure that the garage door is resting firmly against the ground. Open the door and place a 35mm thick block of wood on the ground under the path of the door. Now close the door – if the drive force value is correct the opener will stop and reverse direction upon encountering the block of wood. If too little or too much force is required to make the opener reverse direction – turn the green “Offset” Adjust Pin (4) 5 degrees in the appropriate direction – clockwise (towards Max) to increase the amount of force – anti clockwise (towards MIN) to decrease the amount of force – and then repeat the test.

- **Forced Learn**

May be initiated by holding down the red “Learn” Button (2) for 3 sec – LED Indicator (1) will begin to rapid blink. Cycle the opener through 6 complete uninterrupted strokes in order for it to complete the learning process. The LED Indicator will extinguish once learning has been completed.

- **Automatic Re-Learn**

A re-learn of drive force parameters will be automatically initiated immediately subsequent to either one of the following 3 occurrences:

- a. Run time deviation becoming excessive.
- b. Safety reversing on 3 consecutive occasions.
- c. safety stopping on 3 consecutive occasions.

During this re learn the LED indicator will rapid flash.

M MODE

- **Description**

A less sensitive Safety Reverse system more suited for use suited for use on large, heavy or badly worn doors.

- **Function**

Features conventional one time force adjustment. – during a closing movement the Opener will stop and commence to Safety Reverse upon encountering an obstruction.

- **Enabling**

Switch power off at power outlet.
Remove the light cover.
Select Dip 1 to “OFF” position.

- **Adjustment**

Press and hold down the red “Learn” Button (3) for 2 sec

LED Indicator will commence a paused double blink.

Force adjustment may be carried out while LED Indicator is “paused double blinking”.

Rotate the green “Open” adjust pin (4) to adjust open direction Safety Stop value

Rotate the red “Close” adjust pin (5) to adjust close direction Safety Reverse value – clockwise to increase the amount of force and anti-clockwise to decrease the amount of force. To close out the adjustment mode momentarily press “Learn” (4) button or alternatively the mode will close out automatically after 10 min.

- **Testing**

Follow the procedures outlined in **A Mode Testing**

OPTIONS AND FEATURES

The following section outlines the selectable options and features which are available to the user. The Control Box cover must be removed in order to access the components which control these features. Switch off power at power outlet - hinge down the light cover and remove the single retaining screw and then unclip the cover from its base.

13. Auto Close

Function – Auto Close automatically closes the door, either 5 sec after a car has passed through the doorway or after 30 sec if a car has not passed through the doorway.

To Enable - Select Dips 2 and 3 to the “ON” position.
Note - Auto Close will only function when Safety Beams have been fitted and enabled

13. Courtesy Lamp

Function - Automatically activated each time the Opener is used and then will switch off after 2 min.

Bulb Replacement - Always replace bulb with identical 24V 21W Incandescent

13. Door Service Monitor

Function - Constantly monitors the spring balance of the door and warns the user when door is out of balance. Courtesy lamp will triple flash every 15 sec once imbalance

becomes excessive. At this time the garage door should be serviced by a suitably qualified technician.

To Enable - Select Dip 4 to the “ON” position

13. LED Indicator

Function – The LED (1) provides Opener status information.
Glow Solid – Reached close limit position
Slow Blink – Reached open limit position

Medium Blink – Learning or deleting Hand Transmitters
Rapid Blink – Learning new drive force parameters
Intermittent Blink – Sleep Mode

13. Partial Reverse

Function - Upon encountering an obstruction the opener will commence to Safety Reverse and stop after 300m.

To Enable - Select Dip 7 to the “ON” position

13. Safety Beams

Function - Safety Beams constantly monitor for persons or objects which may cross the path of a moving garage door. The Opener will commence to Safety Reverse when the Safety Beams become momentarily or permanently

interrupted during a closing movement. The Opener will support the connection of 2 or 4 wire Safety Beams.

Connection - Refer connection diagrams

To Enable - Select Dip 2 to the “ON” position.

13. Soft Stop

Function – Reduces the speed of the door as it approaches a limit point ensuring quieter opening and closing.

To Enable – Select Dip 5 to the “ON” position.
Note - This function is only available in A Mode

13. Speed Control

Function – Allows speed adjustment of the Opener to best suit the door type. (Only available in A Mode)

Adjustment – Stop the Opener midway between open and close position. Press and hold “Learn” button (4) until LED (1) begins to rapid blink. Rotate the (red) “Speed” (5) adjust

pin while opener is running - clockwise to increase speed and anti clockwise to decrease speed. Speed may only be adjusted while the Opener is traveling between limits. Adjustment function will close out automatically once either one of the limits has been reached

13. Terminal Connections

Function - The following accessories may be connected;
a. 2 wire Safety Beams (13A)
b. N.O. 24V DC 4 wire Safety Beams (13B)
c. 24V DC universal receiver (13C)

d. N.O. momentary contact wall switch (13D)
e. Warning lamp (6)
f. Additional courtesy lamp 24W max (6)
g. 240V relay driven courtesy lamp (7)

13. Vacation Mode

Function – Disables push button functionality in order to provide utmost security whilst user is absent for extended periods of time.

To Enable – Press button 4 of a mass learned transmitter.
To Disable – Momentarily press either button 1 or button 2 of a mass learned transmitter

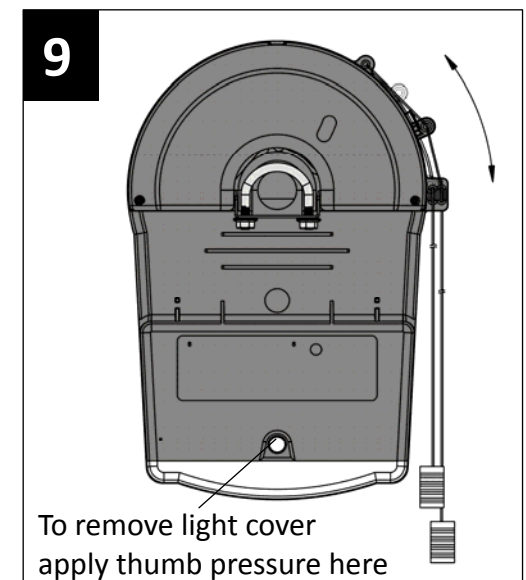
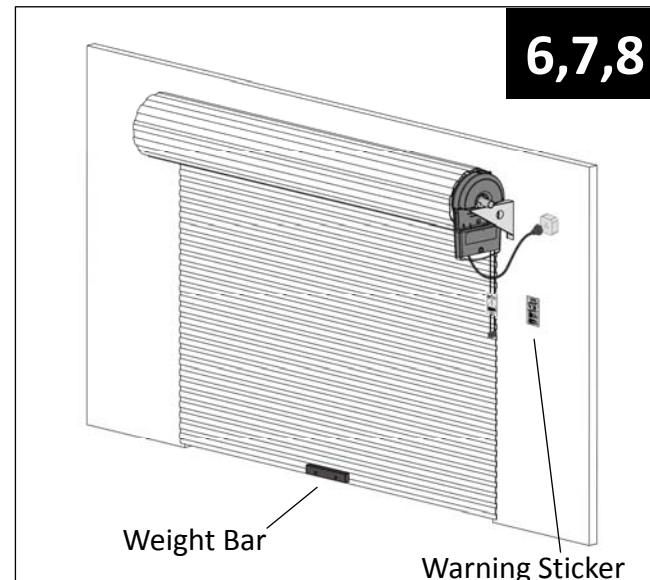
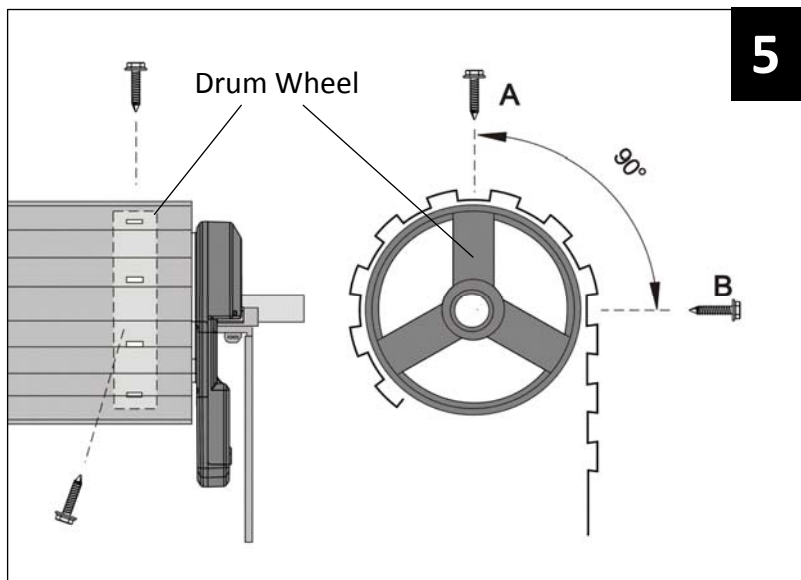
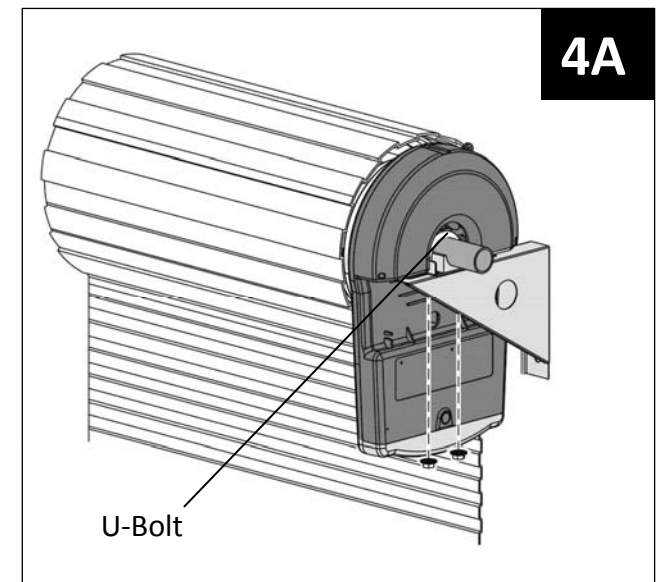
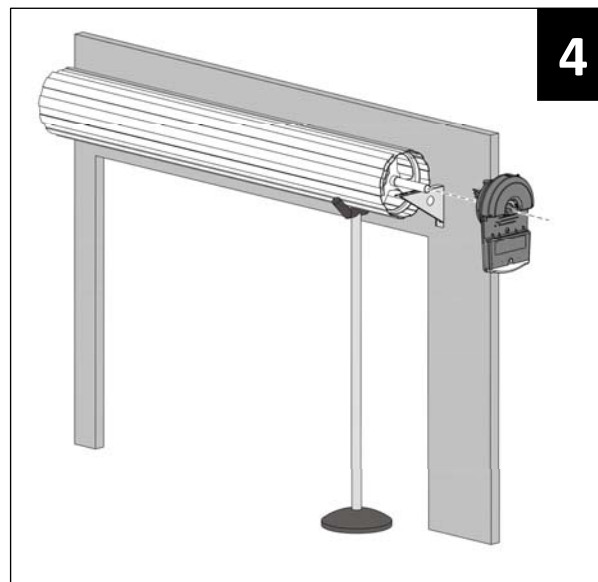
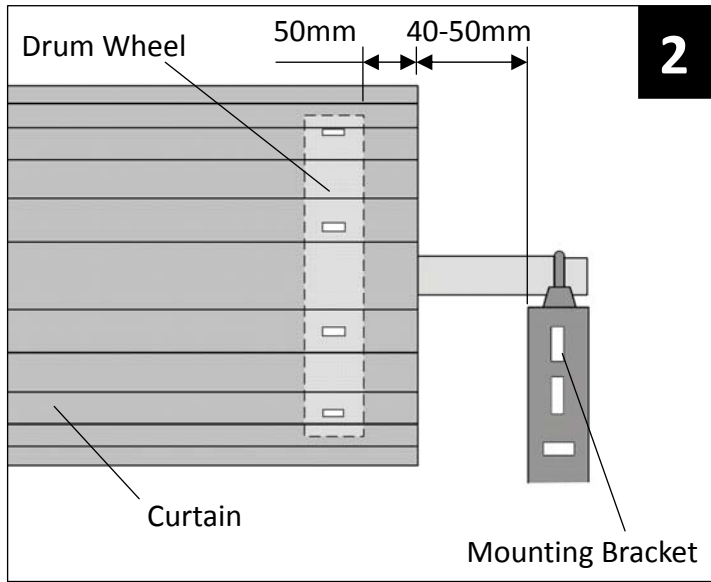

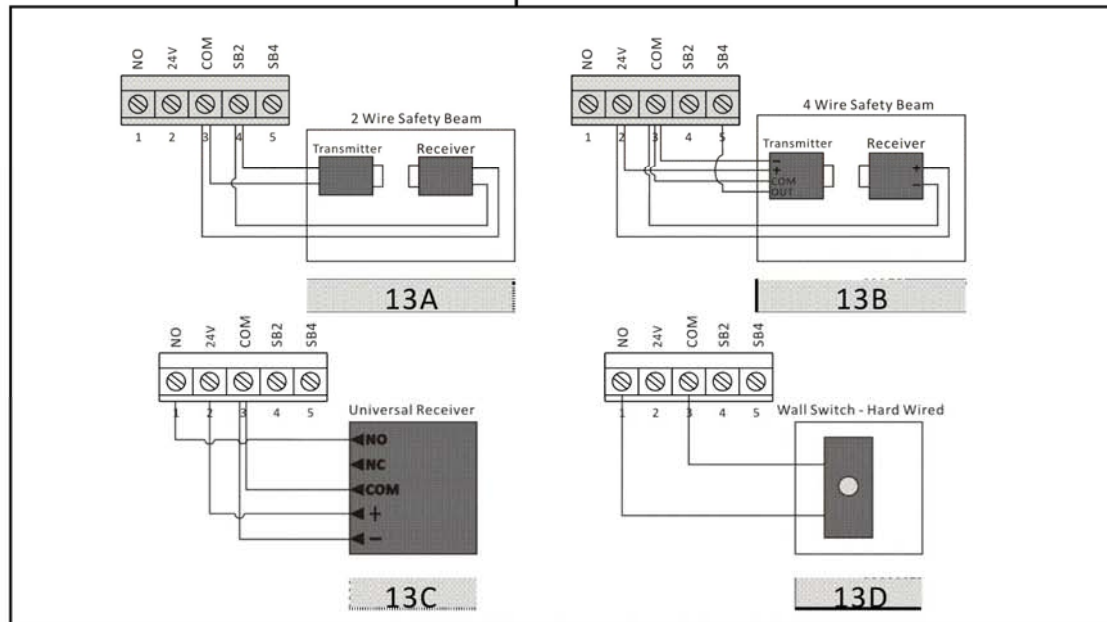
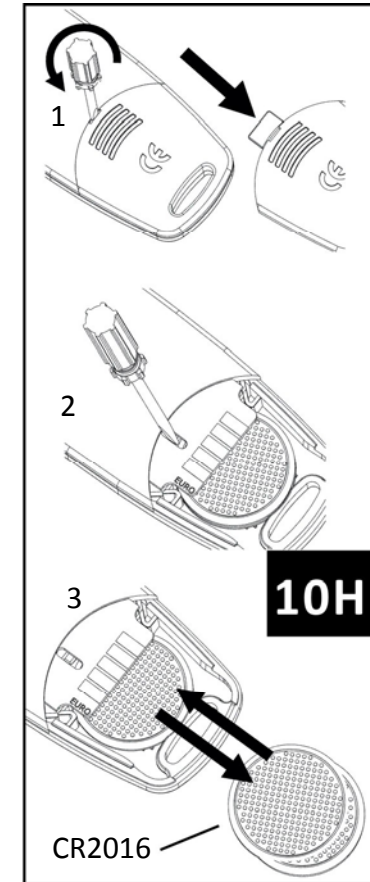
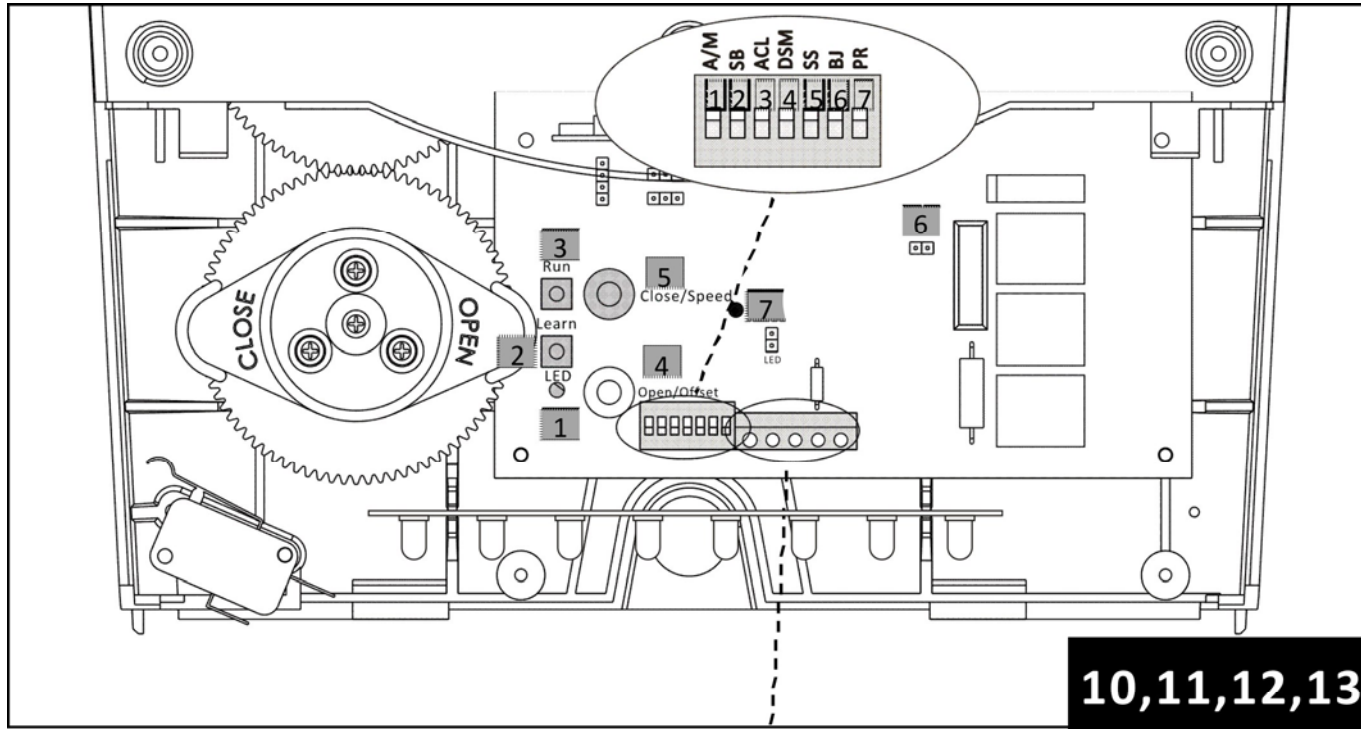

EXPLODED PARTS VIEW

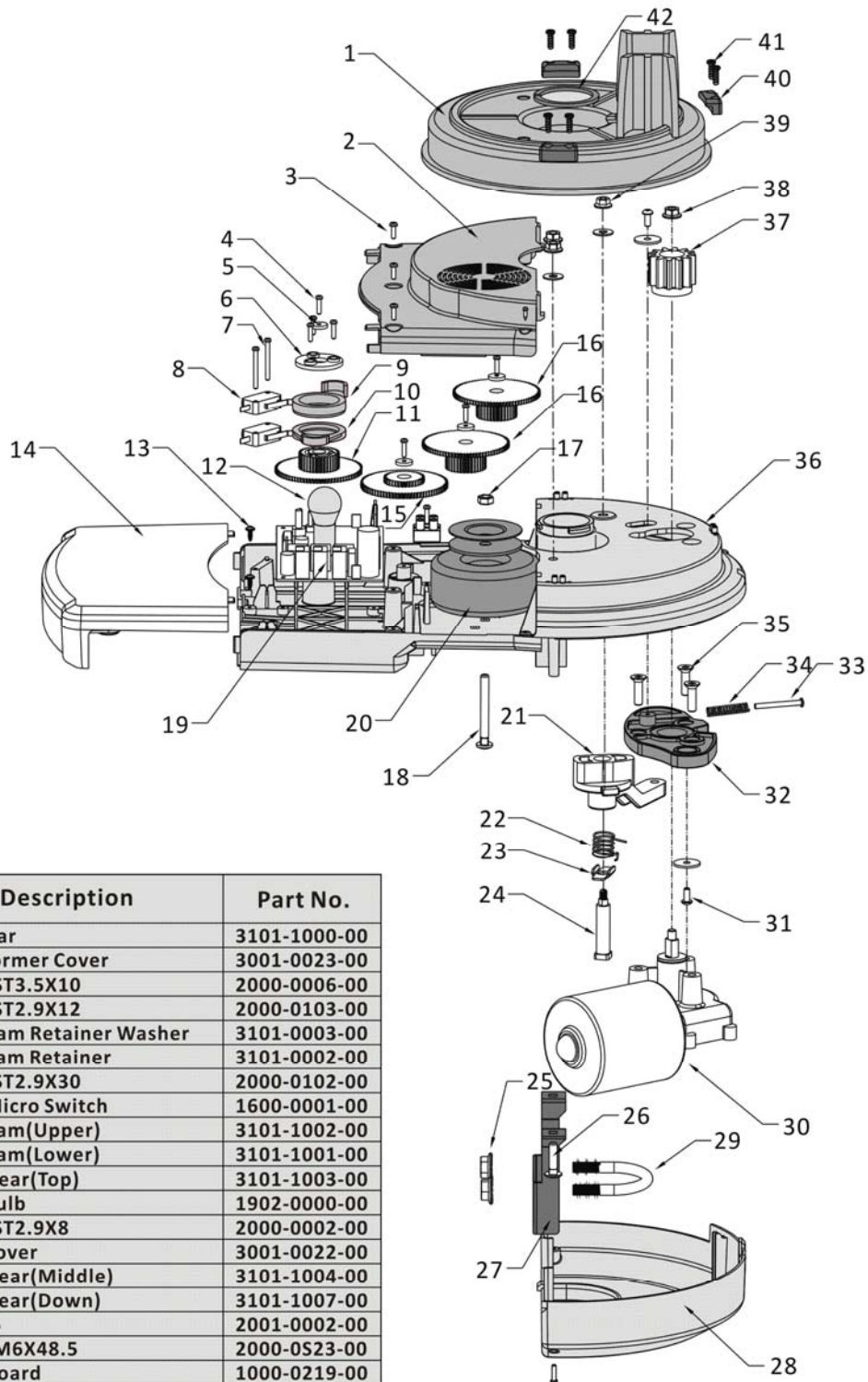

Item	Qty.	Description	Part No.
1	1	Sun Gear	3101-1000-00
2	1	Transformer Cover	3001-0023-00
3	3	Screw ST3.5X10	2000-0006-00
4	9	Screw ST2.9X12	2000-0103-00
5	4	Limit Cam Retainer Washer	3101-0003-00
6	1	Limit Cam Retainer	3101-0002-00
7	2	Screw ST2.9X30	2000-0102-00
8	2	Limit Micro Switch	1600-0001-00
9	1	Limit Cam(Upper)	3101-1002-00
10	1	Limit Cam(Lower)	3101-1001-00
11	1	Limit Gear(Top)	3101-1003-00
12	1	Light Bulb	1902-0000-00
13	2	Screw ST2.9X8	2000-0002-00
14	1	Light Cover	3001-0022-00
15	1	Limit Gear(Middle)	3101-1004-00
16	2	Limit Gear(Down)	3101-1007-00
17	1	Nut M6	2001-0002-00
18	1	Screw M6X48.5	2000-0523-00
19	1	Logic Board	1000-0219-00
20	1	Transformer	1402-0018-00
21	1	Manual Release Lever	3101-0005-00
22	1	Spring	2005-0003-00
23	1	Locating Release Piece	2201-0102-00
24	1	Locating Pin	2004-0500-00
25	1	Nut M8 Wizzlock	2001-0100-00
26	2	Gutter Bolt M6x18	2000-0514-00
27	1	Brace Plate	2201-0103-00
28	1	Motor Cover	3001-0021-00
29	1	U-Bolt(M8 Special)	2000-0501-00
30	1	DC Motor	1101-0007-00
31	2	Screw 4.2x10	2000-0108-00
32	1	Motor Plate	3101-0007-00
33	1	Pin(Motor Plate)	3101-0001-00
34	1	Spring(Motor Plate Pin)	2005-0002-00
35	3	Screw M6x18	2000-0500-00
36	1	Base	3001-0019-00
37	1	Motor Sprocket - Iron	2301-0D00-00
38	1	Nut M6	2001-0101-00
39	1	Nut M5	2001-0103-00
40	3	Sun Gear Plastic Retainer	3001-0024-00
41	6	Screw ST4.2X14F	2000-0101-00
42	1	Retainer(Sun Gear)	3001-3000-00

NOTES

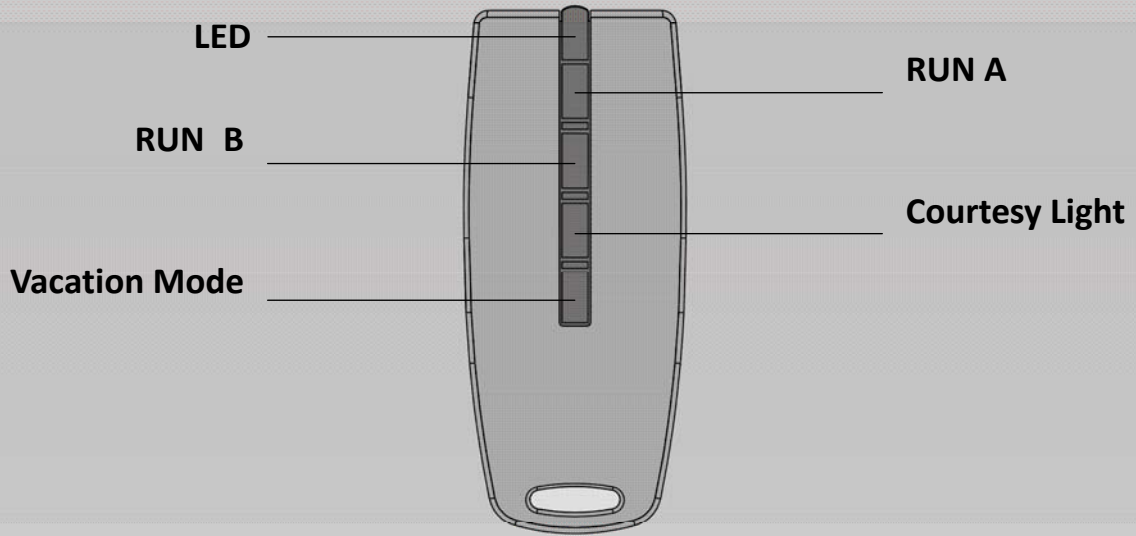

Run A	Refer Sec.8B	Vacation Mode	Refer Sec.8E
Run B	Refer Sec.8C	Battery Replacement	Refer Sec.8H
Courtesy Light	Refer Sec.8D	Transmitter Learning and Deleting	Refer Sec.8A-G

